

piattaforma aerea Ragno 43 metri con verricello

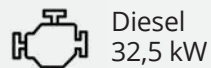

BI-ENERGY



Diesel
32,5 kW



Single-phase
Electric motor
230VAC - 2,2 kW

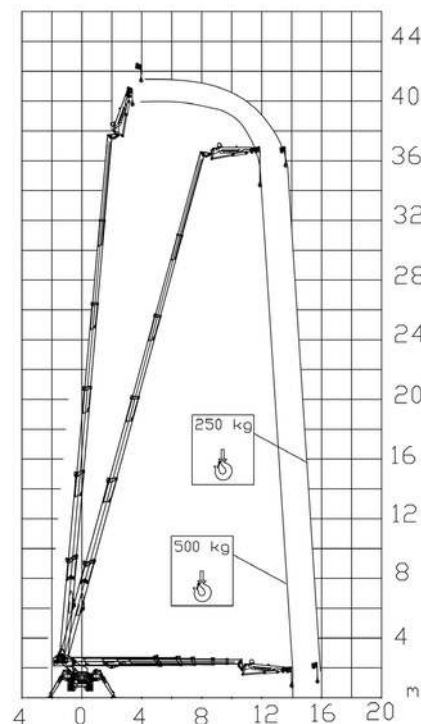

500 kg	250 kg
13,5 m	15,2 m

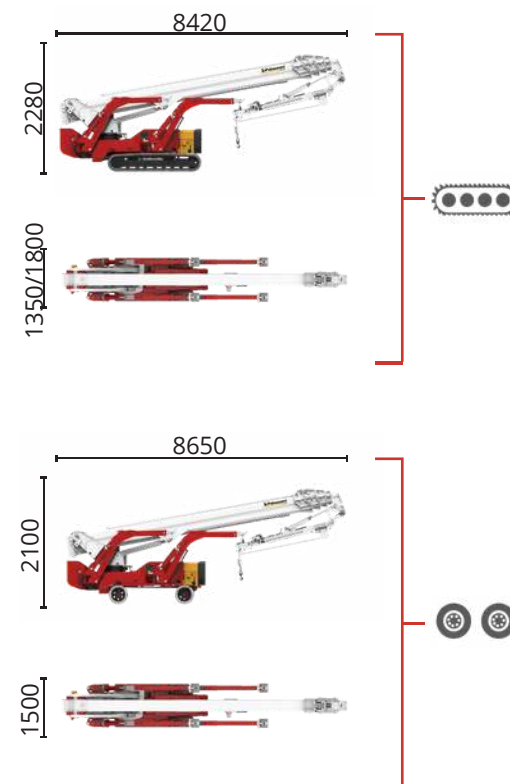

XTJ 43+/C		41,7 m	15,2 m	500 kg	660°	240x70 cm	90°+80°	3,64-5,23 m	23%	38%	2 km/h	10900 kg	75 kN	3,51 kN/m ² 25,39 kN/m ²
XTJ 43+/R		41,7 m	15,2 m	500 kg	660°	240x70 cm	90°+80°	3,64-5,23 m	23%	16%	1,4 km/h	10900 kg	75 kN	3,51 kN/m ² 5,25 kN/m ²

Available power options:

BI-ENERGY (DIESEL+AC)

ECO (AC+BATTERY)



NC 843 A 22

Characteristics and technical data are informative only and subjected to change without notice.



HOIST
VENDITA E NOLEGGIO DI SISTEMI AD ALTA QUOTA

+39 335 8355930

081 18962737

piattaformaaereehoist.it

piattaforma aerea Ragno 43 metri con verricello



ECO

Single-phase Electric motor

Lithium iron phosphate battery LiFePO4

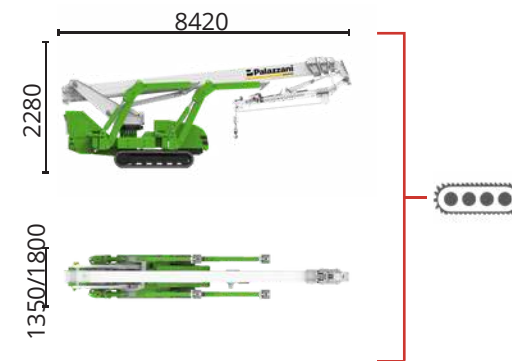
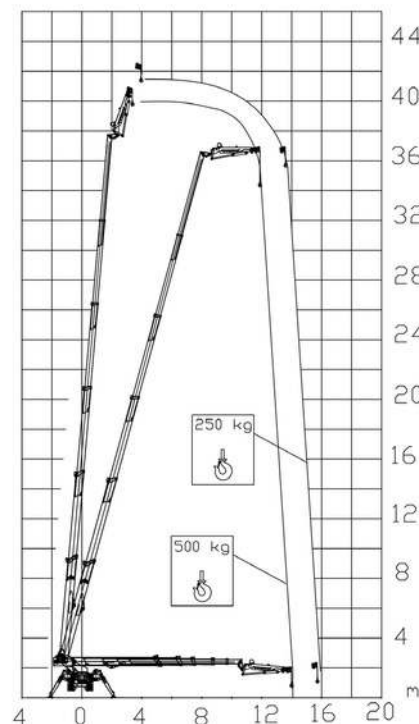

XTJ 43+/C															
-----------	--	--	--	--	--	--	--	--	--	--	--	--	--	--	--

90°+80°

Available power options:

BI-ENERGY (DIESEL+AC)

ECO (AC+BATTERY)



NC 845 A 22

Characteristics and technical data are informative only and subjected to change without notice.

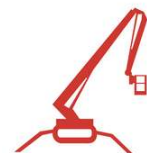

HOIST

VENDITA E NOLEGGIO DI SISTEMI AD ALTA QUOTA

+39 335 8355930

081 18962737

piattaformeareehoist.it